

## V570

### MEASUREMENT BY VOLUME COMPARISON

Without any doubt the most advanced high performance automated volume tester on the market.

Specially adapted to automatic and semi-automatic control, the **V570** has a very complete range of equipment and benefits from the use of the latest technological innovations of the 5 series of instruments.

The **V570** is composed of two equal volumes (T1 and T2) which are constantly maintained at test pressure between two measurements. Following the start of a cycle, T1 and T2 are dumped into the volume to be tested (VT) and the known reference volume (VR).

After a short stabilisation time, the new differential pressure measurement is proportional to the difference between VT and VR. Through its user friendly interface, the **V570** then displays the results of the test either in Pa or in a chosen unit of volume if the calibration procedure has taken place.

#### Highlights

- NEW IMPROVED PERFORMANCE
- OPTIMISED MEASUREMENT
- HIGH SPECIFICATIONS COMPETITIVELY PRICE
- EASY SET-UP



#### Applications



Cylinder heads, cast parts, combustion chambers, piston heads, Carburettor floats, liquid levels (bottling), measurement of filling levels (oil levels)...

# V570

## MEASUREMENT BY VOLUME COMPARISON

### Measurement ranges

VOLUME MEASUREMENT		
Range	Accuracy	Max. resolution
± 500 Pa	±2.5 % of the full scale ± 1 Pa	1 Pa

PRESSURE MEASUREMENT		
Range	Accuracy	Max. resolution
5 - 75 hPa	± 1 % of the full scale	0.1% F.S.

MECHANICAL PRESSURE REGULATION		
from 0,5 kPa to 7,5 kPa		

The base unit is the Pa. The resolution in terms of volume is inferior to 1% of the test volume. The accuracy depends on several calibration parameters. Volume range: from a few cm<sup>3</sup> to 10 dm<sup>3</sup> with accuracies reaching a few mm<sup>3</sup> on small volumes of several cm<sup>3</sup>

### Main features

- Measurement accuracy of a few mm<sup>3</sup> in several litres
- Choice of operation in air or liquid volumes
- Software adjustment of the test and reference circuits through a volume auto zero
- Leak test and simultaneous measurement of volume
- High resolution mode
- Single calibration mode
- Estimation of the volume of the test part
- 16 programs

### Environment

- ROHS standard

### Flexible communication format

- RS232: printer, P.C. and parameter save modules

#### Additional:

Time and date display, choice of languages and units, customisation of tests for your requirement...

### Technical Specifications

Physical	Weight: 15 kg (WxHxD) 537x157x380 mm
Interface	Navigation keys 14 digit displays 4 line LCD display Results indicators
External electrical supply	90 - 260 V AC / 50 W
Air supply	Clean and dry air required Air quality standard to be applied (ISO 8573-1)
Temperature	Operating: +10°C to +45°C Storage: 0°C to +60°C

### Option

- 7 local inputs / 5 local outputs
- 1 quick connector for calibration checking
- 2 pneumatic outputs for control of sealing connectors
- 6 x 24 V programmable outputs for external connection
- 2 analogue current or voltage outputs

### Accessories

- 2 functions remote control
  - Printer
  - ATEQ software (WINATEQ, S5 Demo)
  - Needle valve
  - Calibrated master leaks
  - Filtration kit
  - Sealing connectors
- Please refer to ATEQ accessories list

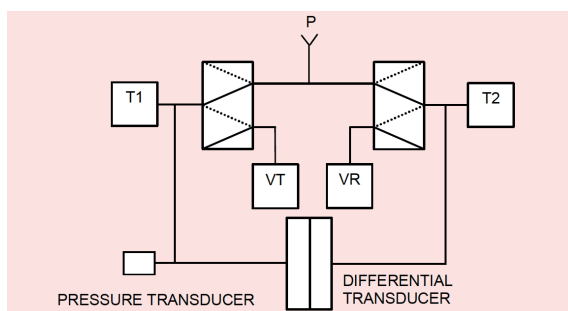

Measurement principles

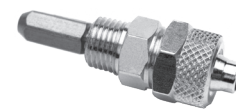

Master jet



Pneumatic coupler

